

SAER[®]

ELETTROPOMPE



AS

CENTRIFUGAL SELF-PRIMING PORTABLE
PUMPS WITH GASOLINE ENGINE



MAIN FEATURES

- Self priming pump
- Robust design with open impeller for solids handling capability
- Integrated suction non return valve to assure priming
- Compact and lightweight for easy portability
- Ideal for several applications: agricultural; industrial, dewatering and many others, especially quick or emergency use.
- Kohler gasoline engine, hard-working SH Series™
- Built to last with heavy-duty crankshaft and cast-iron cylinder liner
- Large-capacity metal fuel tank
- Dual oil fills and drains

PRINCIPALES CARACTERÍSTICAS

- Bomba autocebante
- Diseño robusto con impulsor abierto para manejo de sólidos
- Válvula de retención integrada en la aspiración para asegurar el cebado
- Compacto y ligero para facilitar el transporte
- Ideal para varias aplicaciones: agrícola, industrial, drenaje y muchos otros, especialmente para uso rápido o de emergencia.
- Motor de gasolina Kohler SH Series™
- Construido para durar con cigüeñal para servicio pesado y camisa del cilindro en hierro fundido
- Depósito de combustible metálico con elevada capacidad
- Doble llenado y drenaje de aceite

TECHNICAL FEATURES

PUMP

Model		AS97	AS98
Suction / Delivery		2" / 2"	3" / 3"
Flow	m ³ /h	6 - 38	6 - 48
Head	m	29 - 4	26 - 12
Max solids size	mm	30	40
Impeller type		Open	
Water temperature	°C	-15 / +70	
Max suction lift	m	8	
Impeller		Cast iron EN-GJL-250	
Casing		Cast iron EN-GJL-250	
Mechanical seal		VQ1PFF	
Elastomers		NBR rubber	
Non return valve		Galvanized steel with rubber	

ENGINE

Model	Kohler SH625	
Type	Four-cycle, single-cylinder, slant-cylinder, OHV, air-cooled, gasoline, horizontal shaft, aluminum head and crankcase with cast-iron cylinder liner.	
Gross power @ 3600 rpm	6.5 HP (4.8 kW)	
Displacement	cm ³	196
Stroke	mm	54
Oil capacity	l	0.6
Fuel capacity	l	3.3
Lubrication	Splash	

OPTIONALS AND SPECIAL VERSIONS

VERSION WITH ELECTRIC MOTOR



CARATTERISTICHE PRINCIPALI

- Pompa autoadescante
- Design robusto con girante aperta idonea per la movimentazione dei solidi
- Valvola di non ritorno di aspirazione integrata per garantire l'adescamento
- Compatta e leggera per un facile trasporto
- Ideale per molteplici applicazioni: agricolo; industriale, drenaggio e molti altri, soprattutto per uso rapido o di emergenza.
- Motore a benzina Kohler serie SH™
- Costruito per durare con albero a gomiti per impieghi gravosi e camicia del cilindro in ghisa
- Serbatoio carburante in metallo con elevata capacità
- Doppio riempimento e scarico dell'olio

CARACTERISTIQUES PRINCIPALES

- Pompe auto-amorçante
- Design robuste avec turbine ouverte apte pour le déplacement des solides
- Soupape anti-retour d'aspiration intégrée afin de garantir l'armorçage
- Compacte et légère pour un transport facile
- Idéale pour plusieurs applications: agricole, industriel, drainage et beaucoup d'autres, surtout pour un emploi rapide ou de secours
- Moteur à essence Kohler série SH™
- Fabriqué pour durer avec vilebrequin pour des emplois lourds et chemise du cylindre en fonte
- Réservoir carburant en métal avec grande capacité
- Double remplissage et vidange de l'huile

TECHNICAL FEATURES

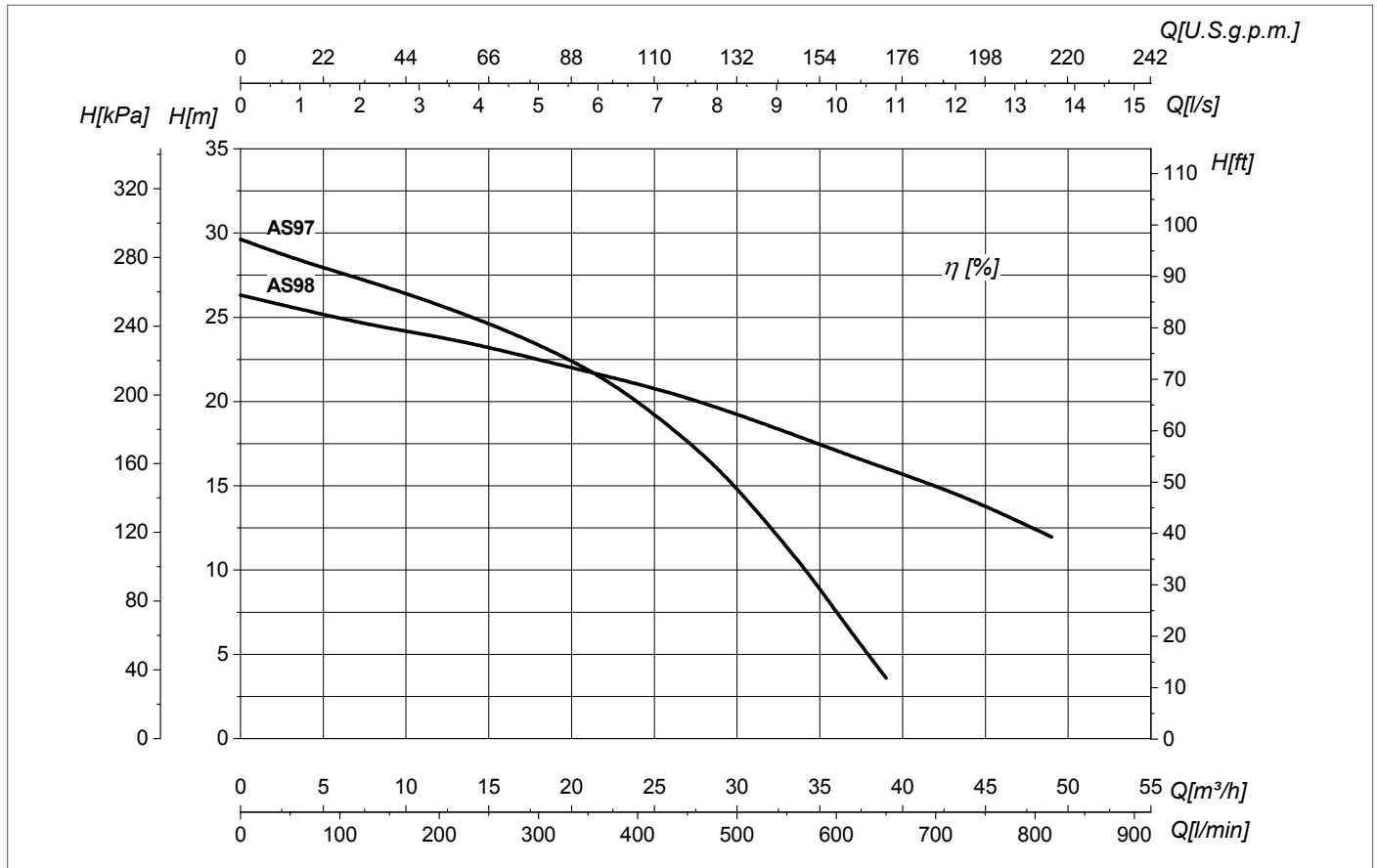

DIMENSIONS

AS97

AS98

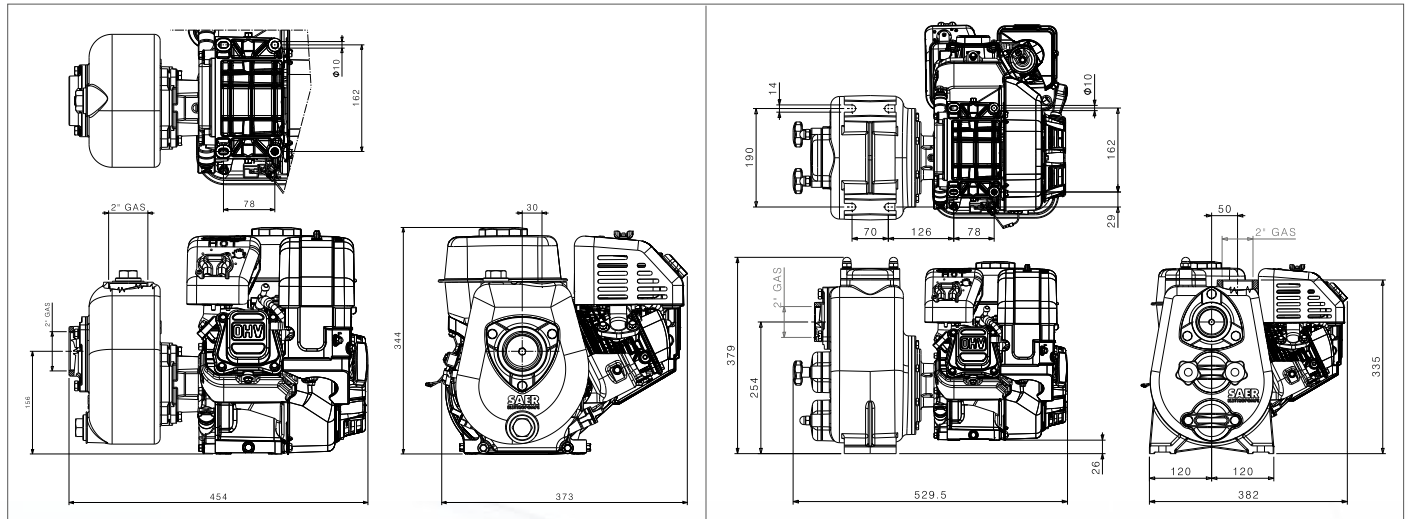

VERSION WITH HANDLING SUPPORT AVAILABLE ON REQUEST

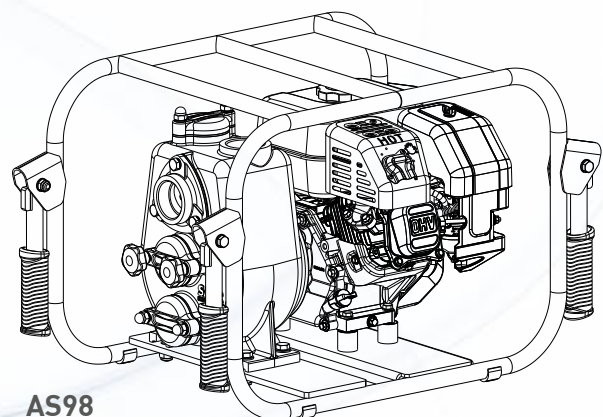
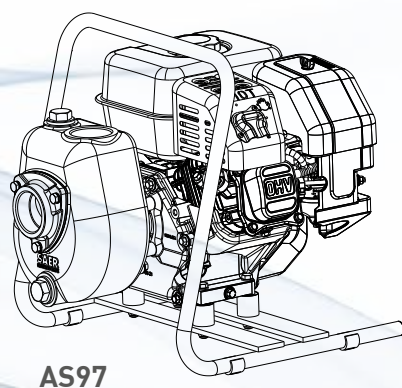

SAER® ELETTROPOMPE

SAER ELETTROPOMPE S.p.A.

Via Circonvallazione, 22 - 42016 Guastalla (RE)
Italy Tel. +39 0522 830941 - Fax +39 0522 826948
E-mail: info@saer.it - www.saerelettropompe.com

 SAER.Elettropompe -  @saerelettropompe -  Saer Elettropompe

 /saerelettropompe -  SAER Pump Selector  



SAER is an ISO 9001:2015
Certified Company
Certificate N. 501003317

