

# SEWAGE GRINDER

submersible pump for  
sewage water



waste water



domestic use

SEWAGE  
GRINDER

**Max Head** 12 - 15m

**Max Flow** 16 - 70m<sup>3</sup>/h

**Motor Power** 0.75 - 4 Kw

**Discharge size** 40 - 80



## KEY ADVANTAGES OF A GRINDER PUMP

### APPLICATION

The electric pumps "Grinder" are particularly suitable for capturing and drainage of rainwater heavy, with solid and fiber. The system grinding ensures that all the solids and fibers "are crushed into small pieces" in order to pass the turbine and the tubes.

### INSTALLATION

Permanent or transportable. Model with float switch control for automatic pump operation, depending on liquid level in the sump.

### MATERIALS

Double seals, lip seals and reinforced SIC-SIC mechanical seal. Motor casing, pump body and open impeller in cast iron, 420 stainless steel shaft. Grinder system.

### PUMPED LIQUID

Water loaded with solids and fibers. Max. liquid temperature: 35°C.

### MOTOR

Fully submersible, pressure tight electric motor. Stainless steel motor- and pump housing. Insulation class F. Motor protection IP 68. Thermal sensors imbedded in the motor winding.

### FEATURES

Power cable: 10 m neoprene for SGR40.  
Power cable: 20 m neoprene for SGR50.  
Immersion depth of 10 m.  
Protection box in monophasic version  
Ideal for installation with guide rail.

# CHARACTERISTIC CURVES AND PERFORMANCE DATA

50 Hz

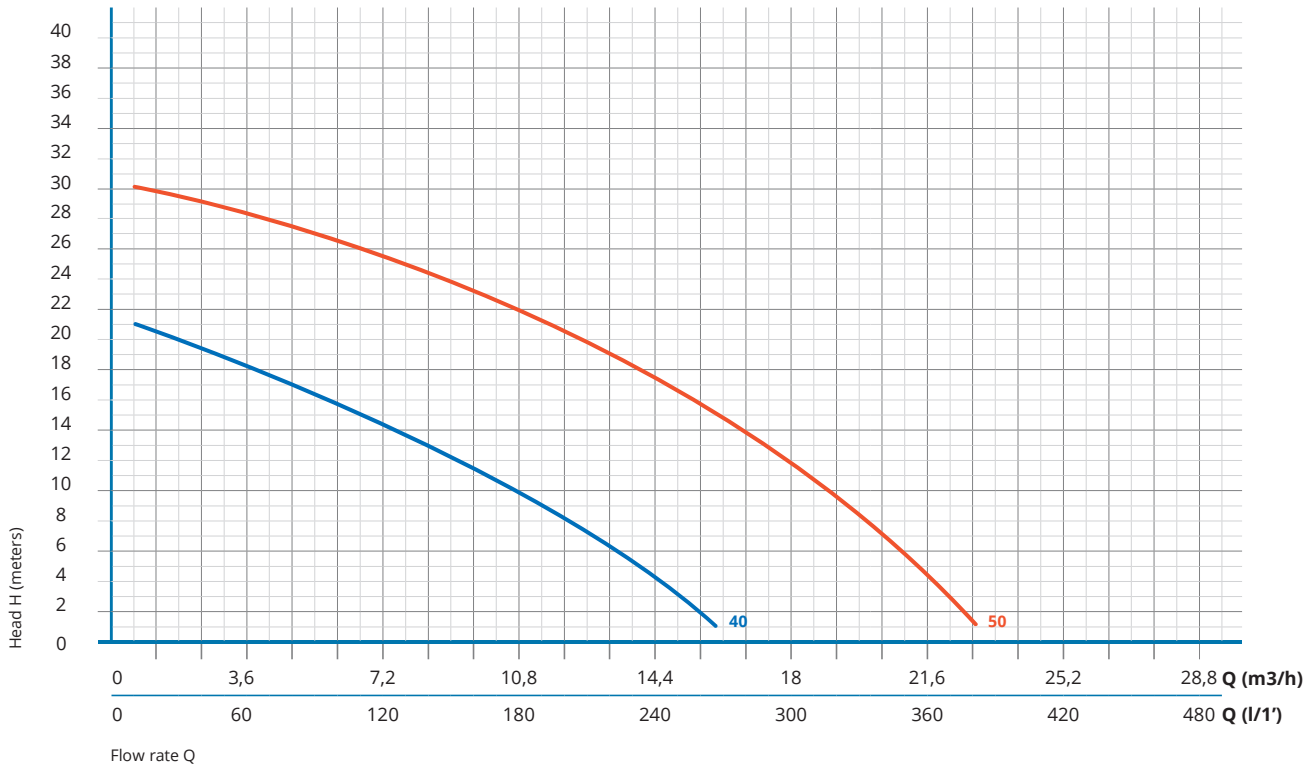

SEWAGE  
GRINDER

TYPE	POWER kW	MOTOR			PORT DN	Q														
		1~ A	1~ µF	3~ A		m³/h	0	1,5	3	4,5	6	7,5	10,5	12	15	18	21			
<b>SGR 40.150</b>	1,5	7,2	35	2,1	1"½		0	25	50	75	100	125	175	200	250	300	350			
<b>SGR 50.220</b>	2,2	10	40	4,6	2															
						H - meters	21	20	18,8	17,4	15,9	14,2	10,3	8,1	3,1					
							30	29,8	29,4	28,8	27,8	26,7	23,6	21,7	17,2	11,7	4,9			

## COMPONENTS AND MATERIALS

### SEWAGE GRINDER

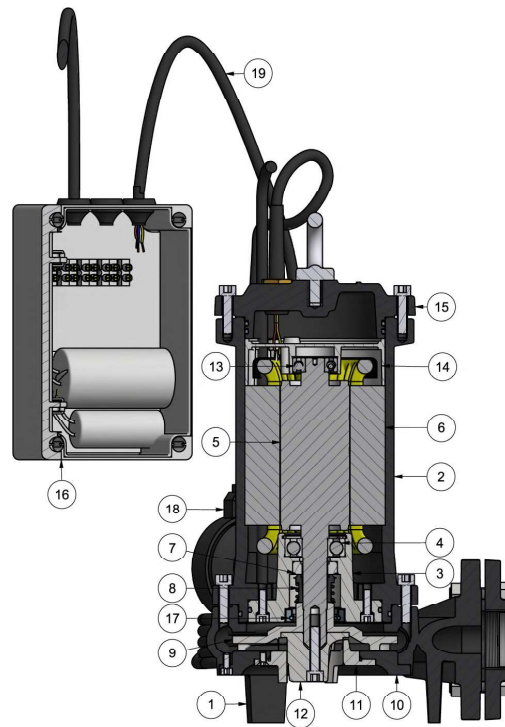

POS	COMPONENT	MATERIALS
1	Body Pump	Cast Iron
2	Motor Casing	Cast Iron
3	Rotor Support SGR	Cast Iron
4	Bearing	Steel
5	Rotor / Shaft	Steel and Aluminium / Stainless Steel
6	Stator	-
7	Mechanical Seal Fixe	Nitrile Rubber / Ceramics
8	Mechanical Seal Mobile	Graphite Steel
9	Impeller	Cast Iron
10	Bottom Cover	Cast Iron
11	Crushed Dish	Stainless Steel
12	Crusher	Stainless Steel
13	Bearing	Steel
14	Top Engine Support	Aluminium
15	Top Cover	Cast Iron
16	Simple Cover Board	-
17	Lip Seals	Nitrile Rubber
18	Float	Neoprene Plastic
19	Power Cable	Neoprene

## DIMENSIONS AND WEIGHT

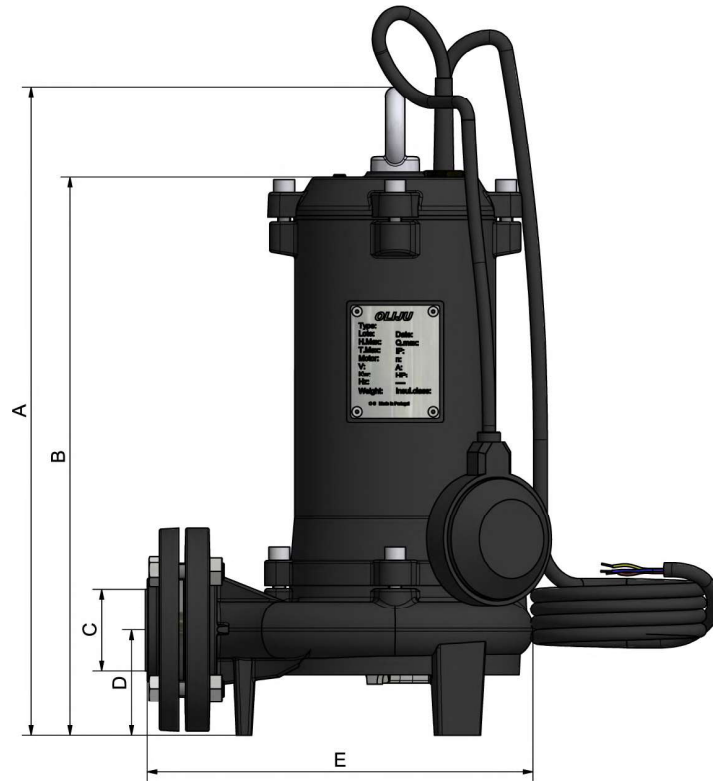

SEWAGE  
GRINDER

TYPE	DIMENSIONS (mm)					WEIGHT Kg
	A	B	C	D	E	
<b>SGR 40.150</b>	402	349	1½"	65	238	26,5
<b>SGR 50.150</b>	470	415	2"	95	294	36