

CISTERNS

AQUARAIN

submersible pump for cisterns



Max Head 30 - 50m

Max Flow 3.6m³/h

Motor Power 0.37 - 0.6Kw

Discharge size G1F



CISTERN
AQUARAIN

KEY ADVANTAGES OF A AQUARAIN PUMP

APPLICATION

The AquaRain series is specially suitable for direct installation at the bottom of tanks thanks to the lower guide of the shaft, in Noryl, and the rubber feet on the bottom of the pump that reduce vibration. The pump can be installed on the flat bottom surface of a tank with a fix or raising strainer.

INSTALLATION

Permanent or transportable. Model with float switch control for automatic pump operation, depending on liquid level. The combination of stainless steel for the turbines and glass fiber reinforced NORYL for broadcasters, provides excellent resistance to abrasion due to sand for maximum efficiency

MATERIALS

Double seals, lip seals and reinforced carbon ceramic mechanical seal. Pump casing, pump head and impellers in 304 stainless steel, 420 stainless steel shaft

PUMPED LIQUID

Clean water.
Max. liquid temperature: 35°C.
Max. sand contents: 60g/m³.

MOTOR

Engine oil immersed food, non-toxic, non-polluting. Externally cooled by the pumped liquid. Insulation class F. Motor protection IP68. Thermal sensors imbedded in the motor winding.

FEATURES

Power cable: 20 m neoprene.
Immersion depth of 20 m.
Max. starts/hour: 30

CHARACTERISTIC CURVES AND PERFORMANCE DATA

50 Hz

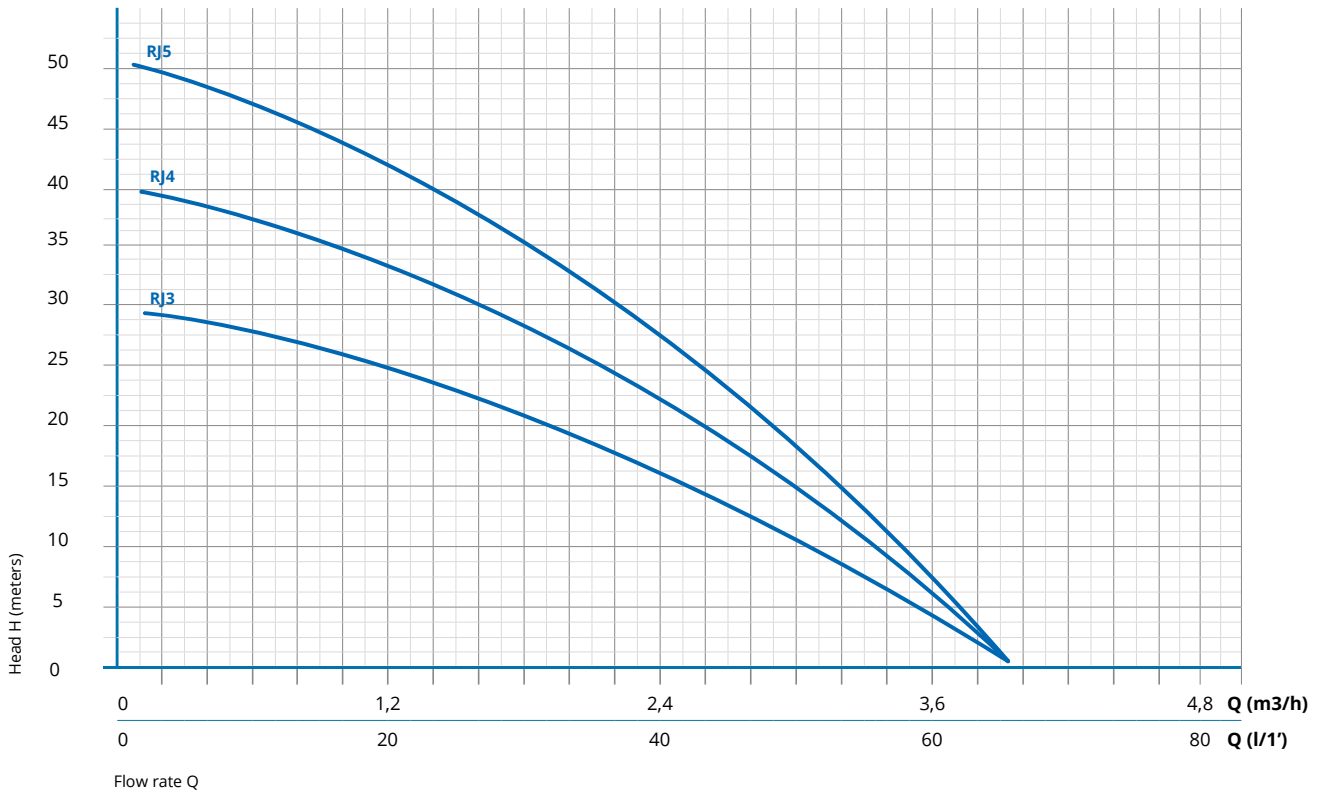

CISTERN
AQUARAIN

TYPE	POWER kW	MOTOR			PORT DN	Q m³/h															
		1~ A	1~ µF	3~ A		0	0,6	1,2	1,8	2,4	3	3,3	4,5	5,7	6	9	10,5	15	19,8		
						l/min															
						0	10	20	30	40	50	55	75	95	100	150	175	250	330		
RJ 3.37	0,37	2,6	12	1,2	1"	H - meters	30	28	25	21	16	11	8								
RJ 4.60	0,6	3,3	14	1,4		40	37	33	28	22	15	11									
RJ 5.60	0,6	4,2	16	1,4		50	47	42	35	28	18	13									

COMPONENTS, MATERIALS, DIMENSIONS AND WEIGHT

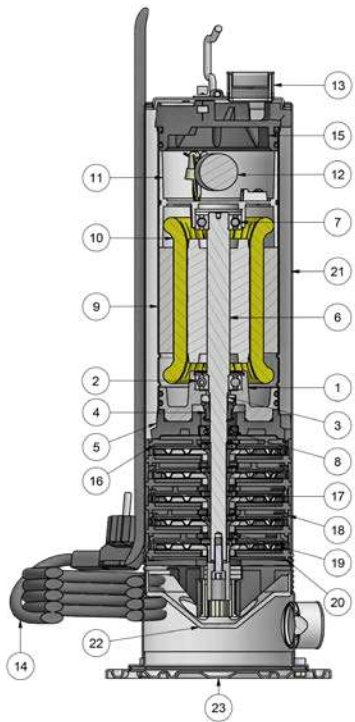

WELLS
AQUALIJU

POS	COMPONENT	MATERIALS
1	Bearing Holder Support	Cast Iron
2	Bearing	Steel
3	Mechanical Seal Fixe	Nitrile Rubber / Ceramics
4	Mechanical Seal Mobile	Graphite Steel
5	Bearing Holder Support	Noryl
6	Rotor / Shaft	Steel and Aluminium / Stainless Steel
7	Bearing	Steel
8	Lip Seals	Nitrile Rubber
9	Motor Casing	Stainless Steel
10	Stator	-
11	Top Engine Support	Aluminium
12	Capacitor	-
13	Outside Higher Cover	Stainless Steel
14	Power Cable	Neoprene
15	Head	Noryl
16	Initial Diffuser	Noryl
17	Impeller	Stainless Steel
18	Diffuser Lid Welded	Noryl
19	Bushing for Impeller	Noryl
20	Diffuser Cover	Noryl
21	External Motor Casing	Stainless Steel
22	Aspiration Support	Stainless Steel
23	Base	Stainless Steel

TYPE	DIMENSIONS (mm)					WEIGHT
	A	ØB	ØC	D	ØE	Kg
RJ 3.37	413,5					8,3
RJ 4.60	449,5	1"	1"	40	170	9,6
RJ 5.60	469,5					9,8